

Aqua & PSPs, HEPs & Dams

- a Symbiotic Relationship

A Globally Unbeatable Range of Submerged Pumps:

upto 750 m

upto 13.2 kV

upto 3000 kW

upto 40,000 m³/hr

With nearly

*75,000 kW of Installations in
PSPs, HEPs & Dams;*

*Aqua's Track Record
is arguably one of the Largest
in the World*

*Best Quality Pump
Vendor*

by



Applications: Pumped Storage Plant (PSP): Construction & Commissioning

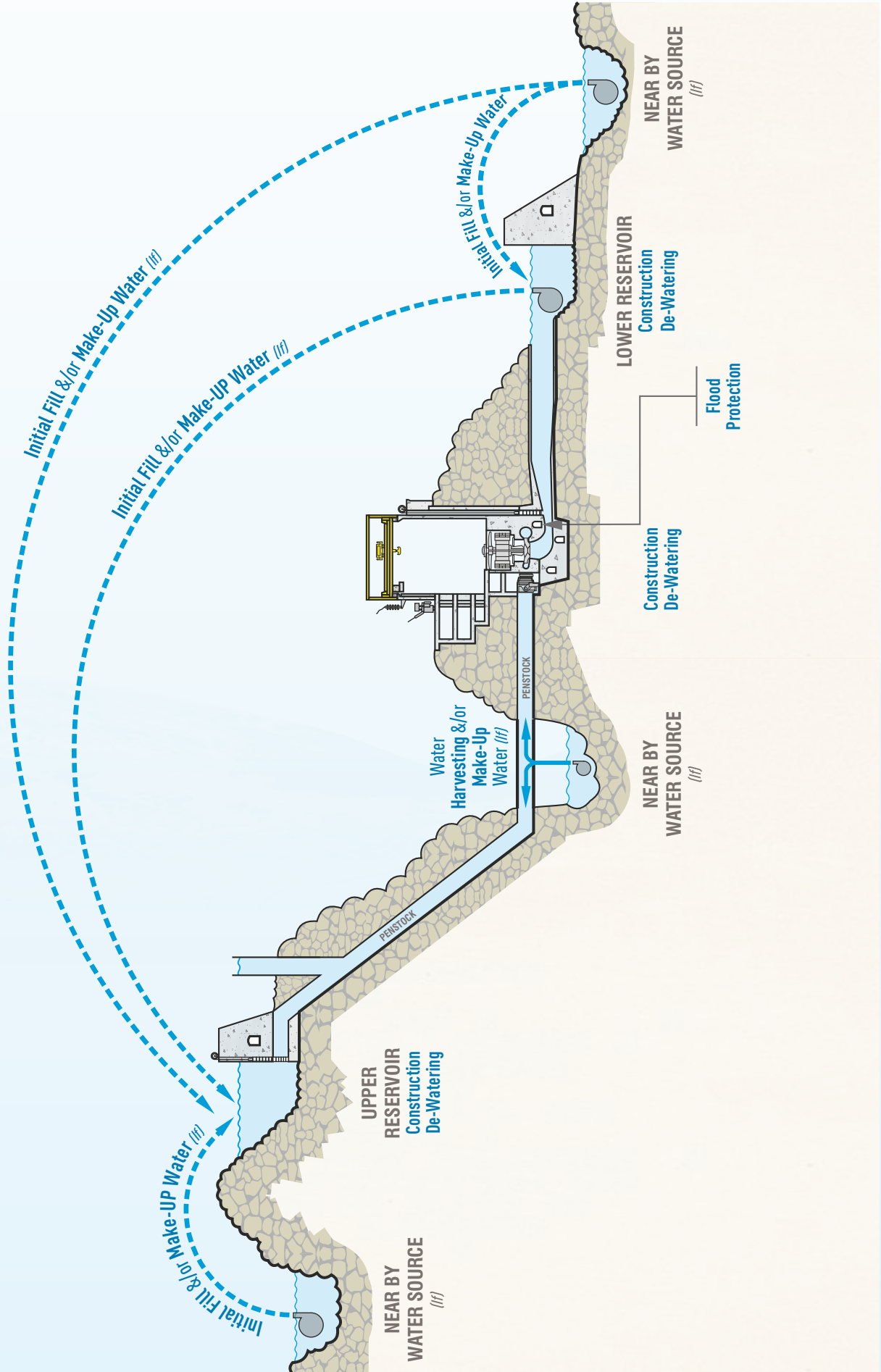

Applications: Pumped Storage Plant (PSP): Operation

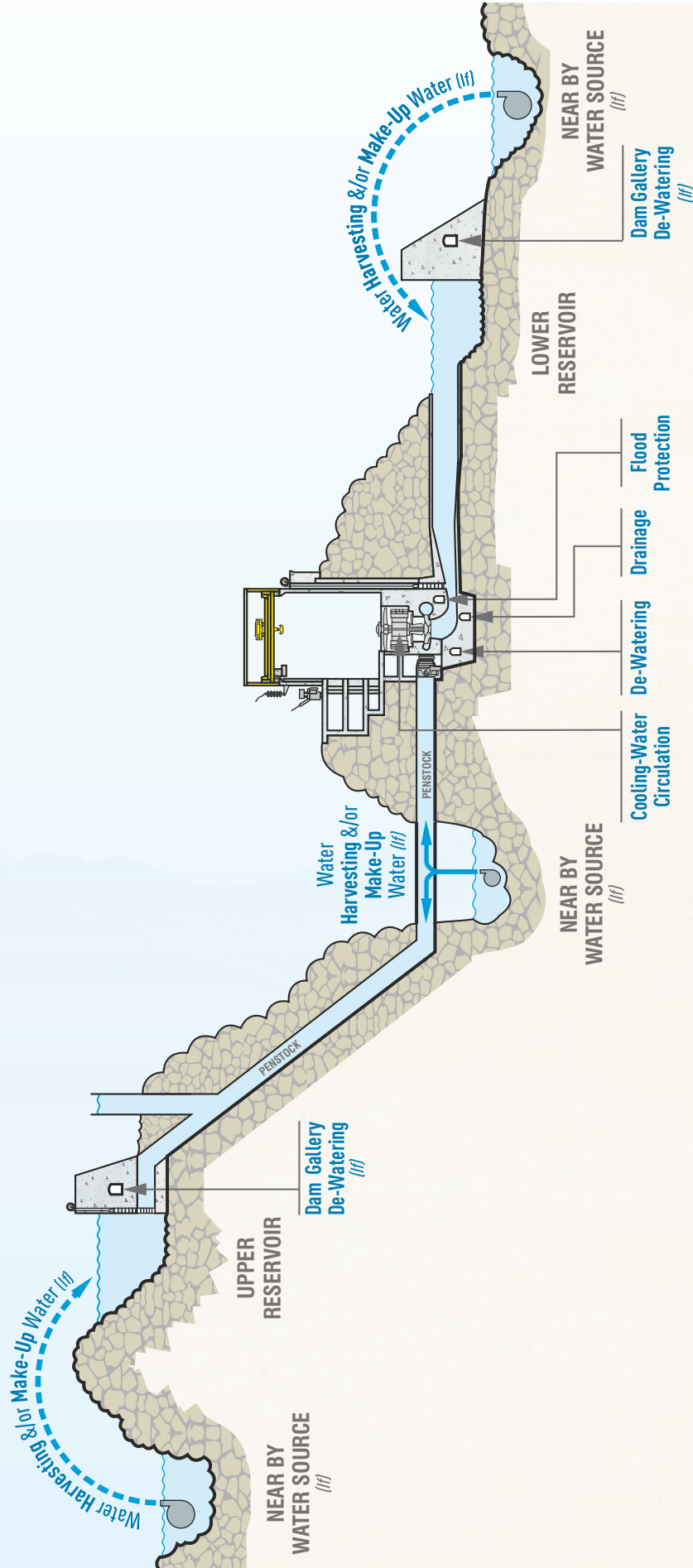

Applications: Hydro Electric Power (HEP) & Dams: Construction

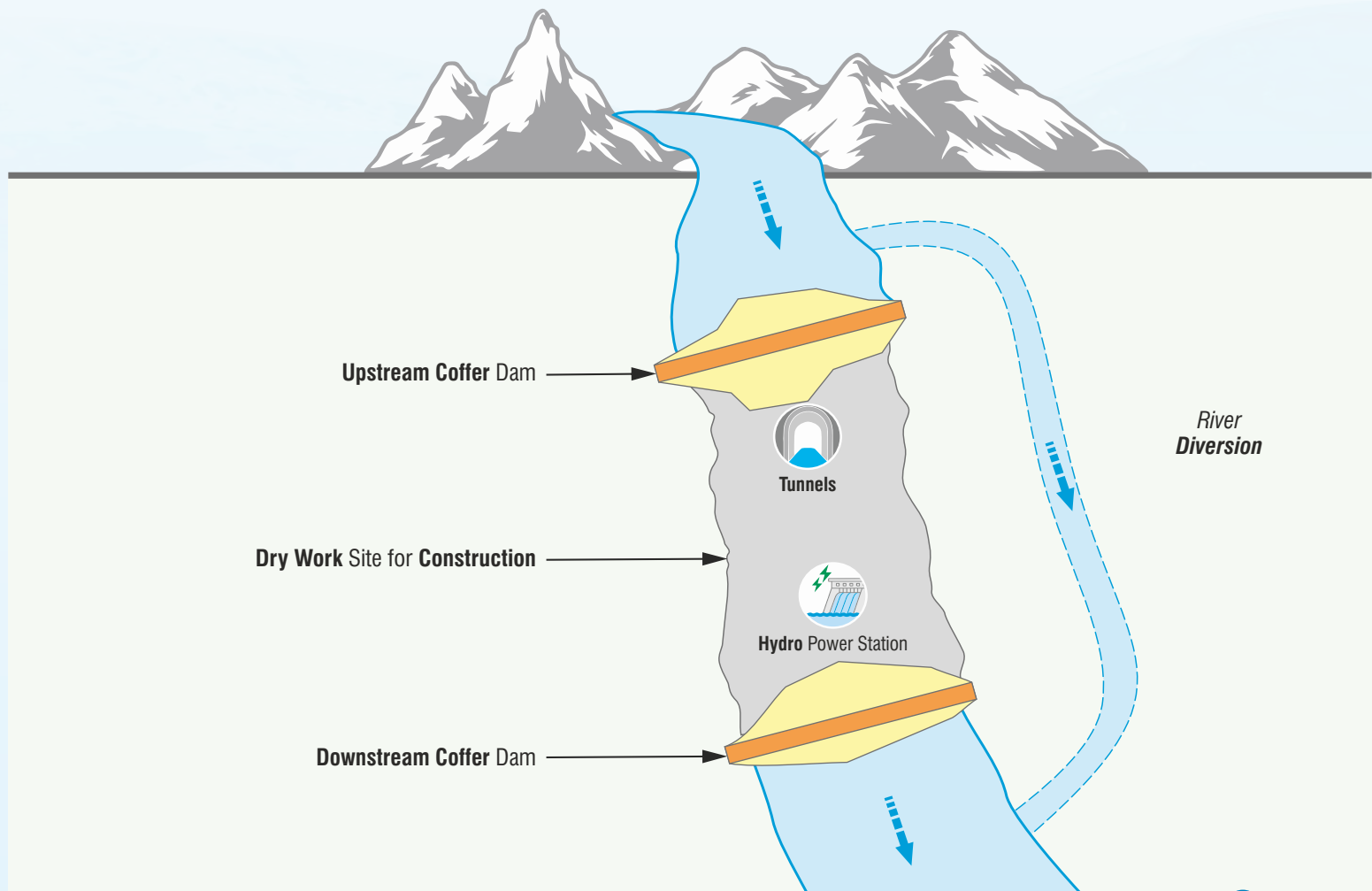
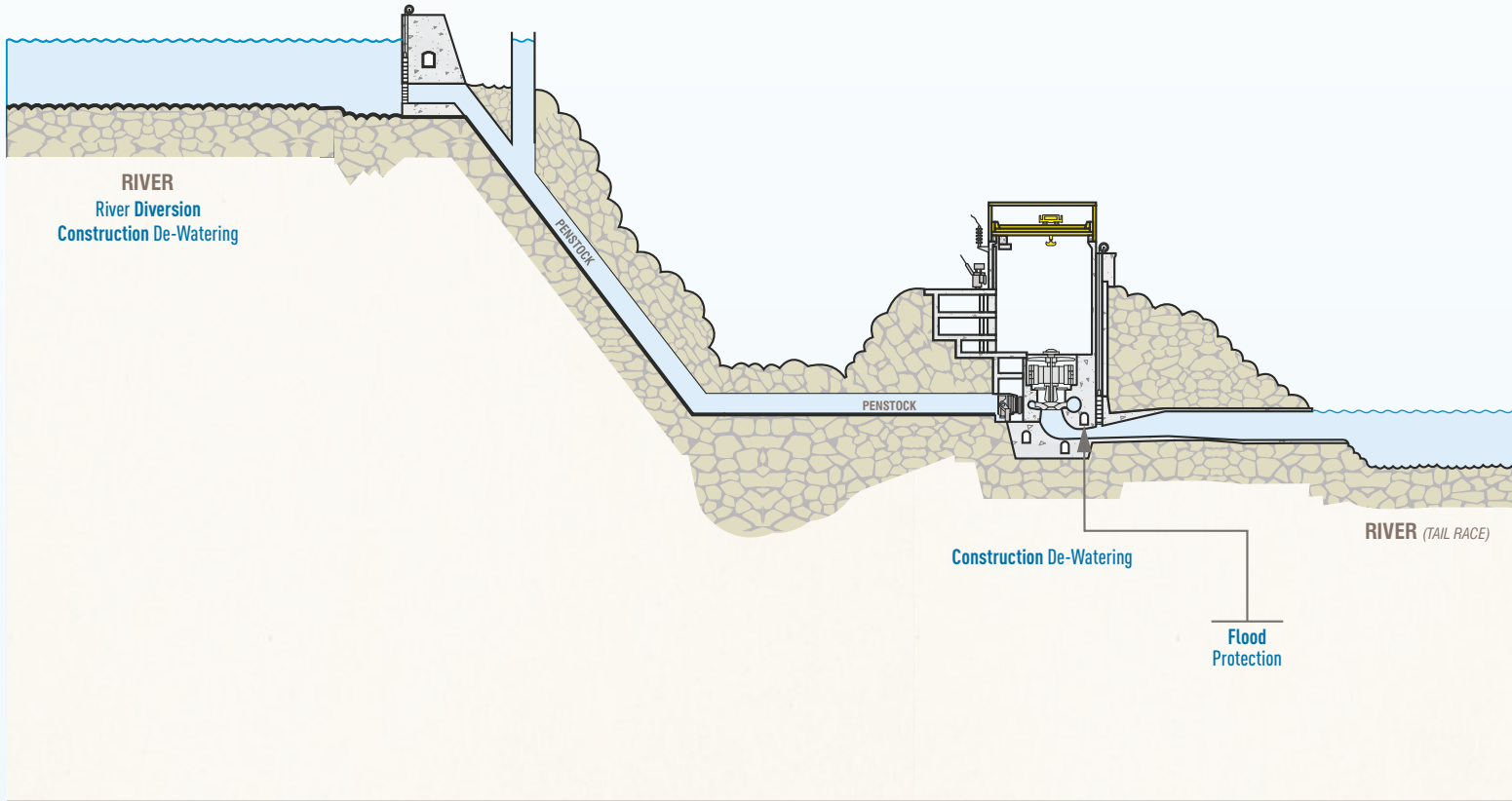

Applications: Hydro Electric Plant (HEP) & Dams: Operation

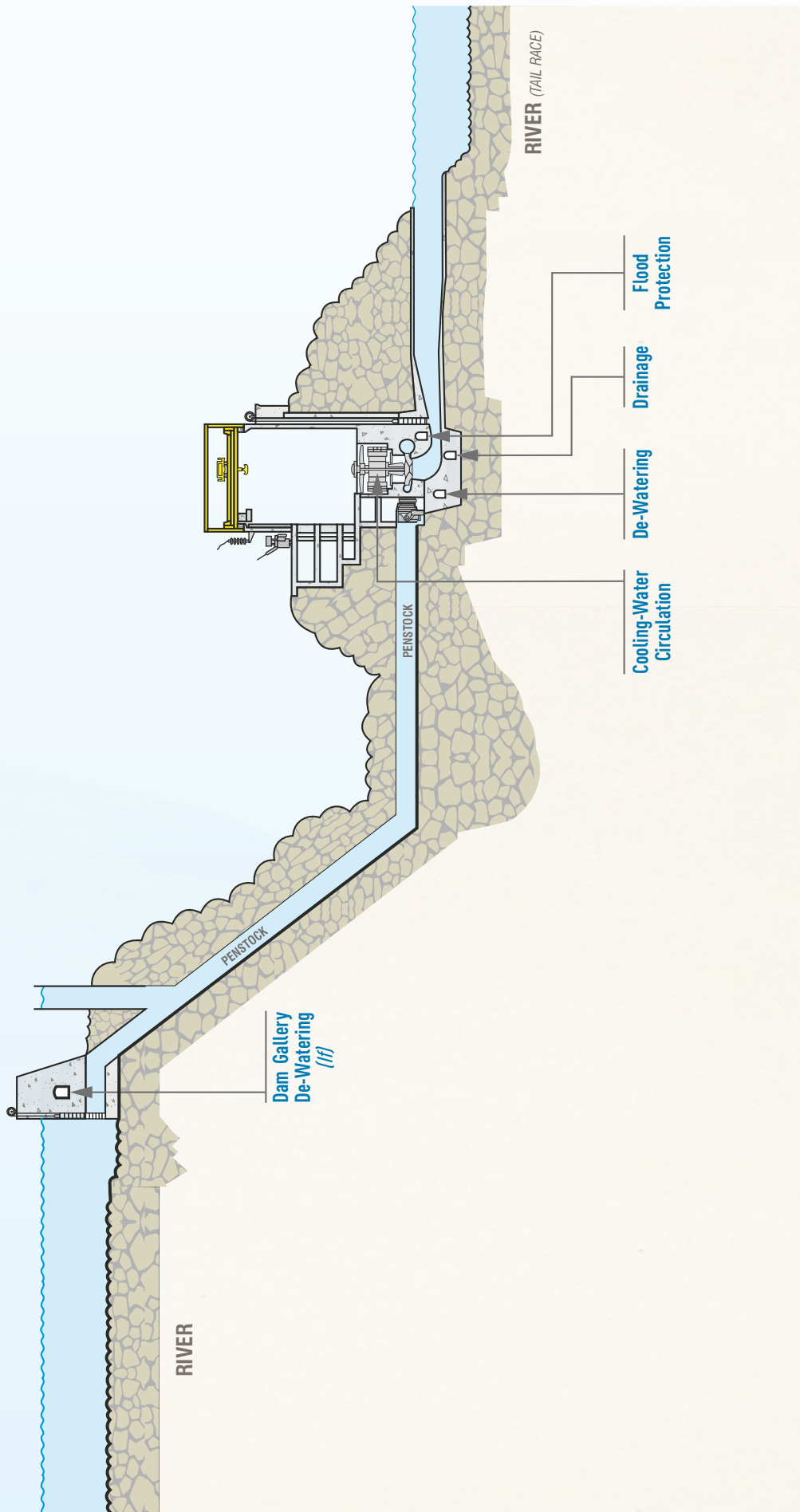

Application wise Pumping Solutions

STAGE	CONSTRUCTION / COMMISSIONING				OPERATION						
	Construction		Commissioning		Drainage	Dewatering	Power House / Machine Hall	Cooling Water	Dam Gallery	Intake	Reservoirs
LOCATION	River Diversion	De Watering	Initial Fill	Flood Protection							
APPLICATION											
PUMP or PUMP TYPE											
Pontoon	✓		✓								✓
ARSES	✓	✓	✓		✓	✓					✓
ARSBS					✓	✓			✓		
ARSDS			✓								
ARS2S			✓								
ARSSO			✓								
ASSHE		✓			✓	✓			✓		
ADSHE					✓	✓	✓		✓		
PDSJ	✓	✓			✓	✓				✓	
ANS	✓	✓									
ANSRA		✓									
AVTB									✓		
AIFPE									✓		
AIFPD									✓		
ARFPE									✓		
PD	✓	✓			✓	✓			✓		✓
PN	✓	✓			✓	✓			✓		✓

Products:



Submerged Centrifugal End Suction, Water Pumpset

ARSES



Bottom Suction, Submerged Vertical Turbine Multistage Pumpset

AVTB



Submerged Centrifugal Double Suction; Water Pumpset

ARSDS



Submerged Centrifugal End Suction, Water Pumpset

ARSBS



Dry Installed, Flood Proof (Fully Immersible) Inline Booster Double Suction Pumpset

AIFPD



Dry Installed, Raw Water Flood Proof (Fully Immersible) Back Pull -Out End Suction Pumpset

ARFPE



Dry Installed, Flood Proof (Fully Immersible) Inline Booster End Suction Pumpset

AIFPE



Submersible Slurry Pumpset

ASSHE

Products:

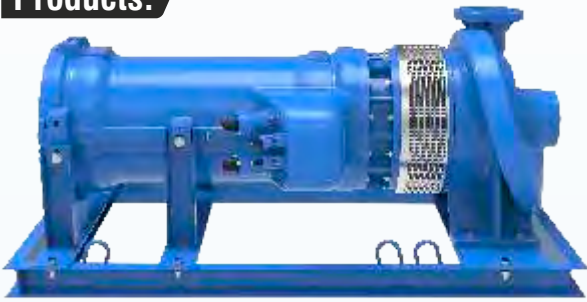

**Portable, Submerged Centrifugal
Two Stage Water Pumpset
ARS2S**

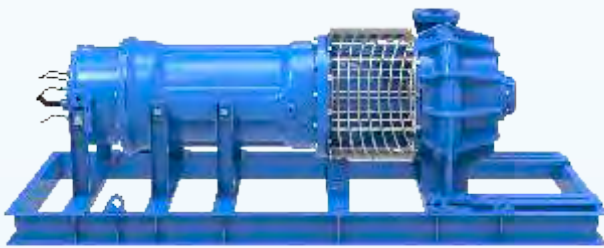

**Portable, Submerged Centrifugal Single
Suction; Opposed Impeller Water Pumpset
ARSSO**



**Submersible Dredging
Pumpset with Agitator
ADSHE**



**Portable, Submersible
Zero Suction, Dredging
Pumpset with Agitator
PDSJ**



**Portable, Non Clog
Submersible Sludge
Pumpset
PN**



**Portable, Zero Suction
Submersible Contractor
Dewatering Pumpset
PD**



**Submersible
Non Clog Pumpset
ANS**



**Submersible Non Clog
Pumpset
ANSRA**

Plant:

*One of the World's **Largest** &
(in terms of Area & Quantity of pumpsets)*

Largest Plant

(in terms of pumpset's Ratings)

exclusively

dedicated to Dry Motor Submerged

Pumpsets....



A Globally Unbeatable Range of Submerged Pumps:

*upto **750 m***

*upto **13.2 kV***

*upto **3000 kW***

*upto **40,000 m³/hr***

Aqua is One of the **Global Leaders** in Manufacturing of Large Rating Submersible/ Submerged Motor Pumpsets.

Aqua has successfully substituted and in many cases; even bettered the Performances of many “European” Submersible Pumps most of which are based on simple “Sewage” or “Clear Water” pump hydraulics.

The "HE" (*Hydro Electric*) Series of Aqua's Pumps are purposely Over designed to perform with **Bullet Proof Reliability** under the Arduous Conditions prevalent at PSPs, HEPs & Dams of **Global South**; they...

- ... are Portable & Compact, therefore Quick & Easy to Install
- ... can **Tolerate Higher Silt** often encountered in Himalayan rivers
- ... can **Tolerate Calcite Crystallizations** often encountered in water oozing out of Cement Dam Galleries
- ... can also be used to **Remove Settled Silt** (*only ADS HE, ADSJ Pumps*)
- ... can Safely **Tolerate Deeper (40m/75m) Water Submergence** (*Encountered during Power House Flooding*)
- ... require **Very Low Routine Maintenance** (*Compared to Conventional Vertical Turbine/ Centrifugal pumps*)
- ... are **Economical** in both CAPEX as well as OPEX
- ... even our Dry Installed pumps are **always Flood Proof**
- ... operate **Silently & Smoothly**
- ... require Lesser Civil Footprints, resulting in **Savings of Civil Works**

Benefits:

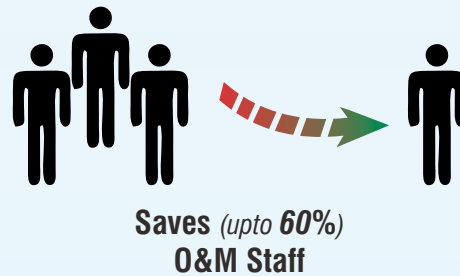
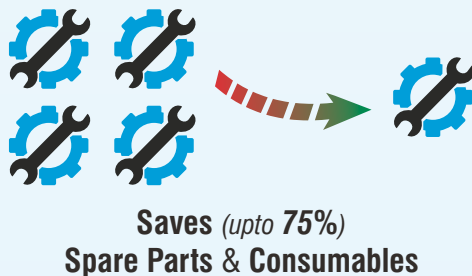
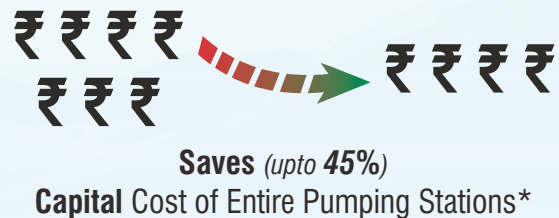

Low Energy Cost



No need for Frequent Periodic....



Shafts/Sleeves &/or Coupling



Gland Packing



Oil &/or Grease



PSP

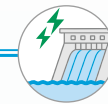

HEP

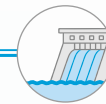

Dam/Barrage



User Friendly

- No Risk of Cavitations.
- No Damage due to Flood's



Low Life Cycle Costs



Minimal Noise, Vibration & Heat Emission; due to **Elimination** of Auxiliary & Ancillary systems (like Forced Water Lubrication, Thrust Bearing Cooling system, Motor Heat Exchanger).

**(refer marketing@aquapumps.com for additional white papers)*



Requires No Special Pre – Post / Ancillary-Auxillary Operations; like :

- Operating & Maintaining the Forced Water Lubrication systems operation,
- Operating the De-watering Pump to water leakage from Seepage / Gland Piping Leakage, etc.

Applications:

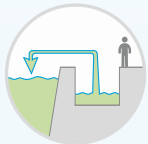

Flood Protection
(Disaster Management)

Flood Proof Insurance in case of Accidental Flooding to Avoid Catastrophic Human & Capital Loss.



Flood Proof Insurance

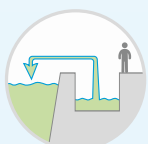

Plant De-Watering

De-Watering



Construction De-Watering

AQUA Dewatering Pumps are Designed to Dewater :

- Enormous Quantities of Water from Penstocks, Turbines & Tail Race in a very short time (for Plant Maintenance).
- Keep the Construction Site Dry / Divert the River during the Construction phase.



River Diversion

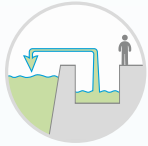
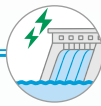

Drainage

(During Plant Operation)

AQUA Pumps are designed for 24 x 7 Operation to Drain-out Seepage from Concrete, Turbine Gland Leakage, etc. from Machine Rooms and Dam Galleries during Operation, Planned Maintenance and Emergency.

Minimum Operational Hassles.....



No risk of Motor Burnout under Water Accumulated from Leakage of Piping &/or Pump's Gland &/or pump's Gasket &/or Seepage from Wall (even after Lack of Frequent De-Watering) due to Operator's Absenteeism &/or Failure of De-Watering System for Floods.

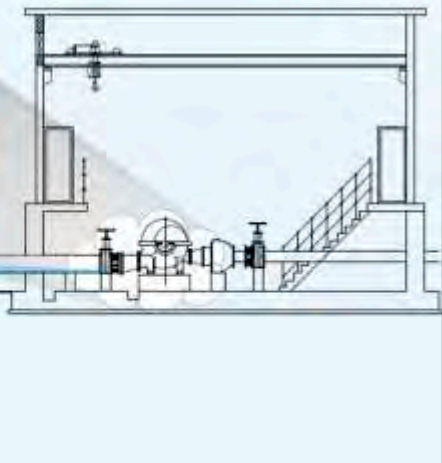
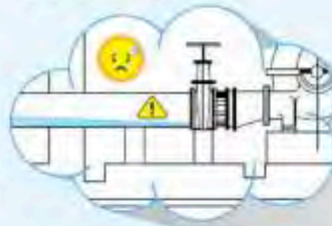

Pumps in HEPs, PSPs & Dams; can be buried under settled Silt &/or even **Crystallized Calcites** which can then Jam, Seize or Severely Erode pumps reducing their discharge pressure, Breakdown of Pump bearings (if they are water lubricated) and Hamper the ability of Motor to start-up the Pump (as it is buried under silt & has to start-up at reduced head condition without valve throttling).

Aqua's Pumps are Non-Galling & Seizure Resistant (as bearings are located deep inside the Hermetically sealed Motor) and Designed for such arduous conditions.

Aqua's Auto Coupling System is Quick & Simple Replacement of any Pump thereby ensuring Minimal Pumping Downtime.

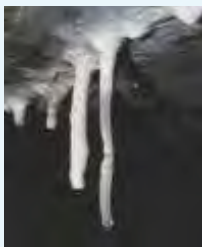

Aqua's Pumps can...

...tolerate **Higher Silt Levels**

...remove **Settled Silt**

...tolerate **Higher Calcite Deposits** (often encountered in new constructions).

...tolerate **Deep (upto 40m/75m) Water Submergence** (encountered during flooded power house).

...require **No Routine Maintenance.**

...can tolerate **Wide Head Range Variation.**



Aqua's pumps have :

- Steep Natured Head Flow performance curves,
- **Reinforced Shaft**, Heavy Duty Greased for Life Bearings &
- it's Motors have **High Inbuilt Reserve Margins;**
- Anti Vibration Fastening methods;

enabling them to be Started & Used with Wide Head Variations.



Robust & Reliable

No breakdown even in High **Silt**, **Rust & Calcite** levels.



Zero Aging

Mechanical Shaft Seals are Calcite, Silt & Rust Resistant. Bearings are Greased for Life.



Ultra Low Maintenance

• Requires No Consumables or Routine Maintenance (like Oil, Grease, Bush, Sleeves, Auto Coupling Rubber Gaskets, etc)



PSP

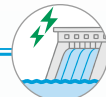

HEP



Dam/Barrage



Initial Fill
(During Commissioning)

Make Up Water
(MUW) (During Operation)

Aqua's Submerged Pumps mounted either on Aqua's Pontoons or Directly in Water Body are the Most Economical, Quickest & Simplest Solution.

Aqua has Lifted 1.4 TMC / 444 MLD / 18,494 m³/hr Water for the Initial-fill of the Lower Reservoir at World's Largest IREP at M/s. Greenko's Pinnapuram in Time bound fashion under Challenging & Unforeseen (*El Nino*) Conditions.



Fixed installation or Floating installation i.e. Pumps mounted on Pontoon, **AQUA** is End-to-End Solution Provider for Initial Fill and Make Up Water applications.

Synchronization of
Hydraulic Engg + Pump + Pontoon + Walkway + Electricals + Piping
system design under a SINGLE ROOF for
Turnkey Responsibility &
Harmonious System Performance



Pontoon Pumping Station:



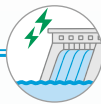

PSP

HEP

Dam/Barrage

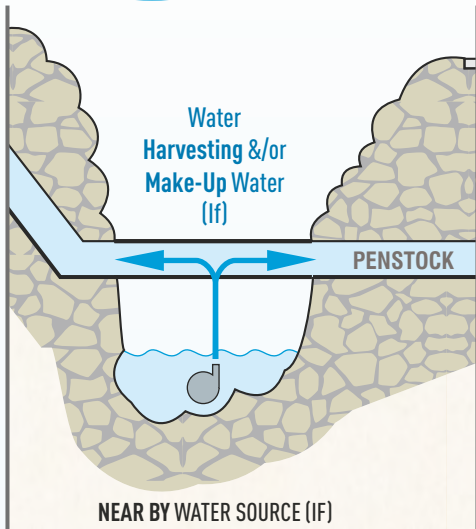

Water Harvesting (During Operation)

PSPs & HEP's on Non-Perennial Rivers (especially those with many surrounding yet non-linked water bodies) can benefit from Water Harvesting; Water from these nearby Rivulets/ Drains/ Reservoirs (which do not feed either of the Upper or Lower Reservoirs).



Such water can be economically & easily Pumped to the Reservoirs or Penstock from where it shall feed the Turbine thereby resulting in Power Generation (HEP) / ReGeneration (PSP).

Aqua's SubCF Pumps are used to Catch Run-Off Monsoon Waters from Non-Perennial Rivers, Rivulets & Pressure Inject them directly into the Penstock at Tata's Bhira HEP / PSP - India's Oldest Hydro Power Station.



Cooling Water (CWS) (During Operation)

Aqua's Pumps for handling Cooling Water (either Wet or Dry Installed) are designed to work Round the Clock with High Efficiency, both for Open Loop or Closed Loop Cooling Water Systems.

When installed Wet, they save a huge amount of Civil Cost. When installed Dry – i.e. within the Power House, as compared to Conventional Bare Shaft Non Immersible pumps; they offer benefits of:

- **Reduced HVAC Load** (as the Motor Pump Heat is disposed off in pumped water & not in the Power House Cavern)
- Being **Flood Proof**, Ultra Low Maintenance & Leak Free

TECHNICAL DATA SHEET OF PUMP
FOR SUBMERSIBLE TYPE COOLING WATER PUMP MOTOR SET, RAMMAN-III HEP (3 X 40 MW)

P.O Number:- 1388064
P.O Date:- 08-12-18

Annexure - A
PI NO : 340283616

1	Make / Pump & Model No.	AQUA Make:- ASSNE V AC, 1st_Vol_1542_T_M_0990_00415_01
2	Type of Pump	Submersible Pump
3	Number of Stages	Single
4	Starting loss cooling arrangement	Mechanical Seal
5	Quantity of Pumps	0 Non
6	Orientation of suction and delivery ends	Vertical bottom suction and Horizontal Side Delivery
7	Gilt of Pumps (kg-m)	2.6
8	Temperature of operation	Min. 4°C, Max 35°C
9	Capacity (m ³ /hr) (Rated)	426 m ³ /hr
10	Total head generated at duty point (m)	30 mtr.
11	Shut off head (m)	30.3 m approx.
12	Head / Stage (m)	30 m / Stage
13	Hydrostatic test pressure (kg/cm ²) for casting	2 times of duty point head or 1.5 times of shut off head whichever is higher, for 30 minutes minimum.
14	Pump efficiency (%) at duty point of Pump	76 %
15	Min scale flow (m ³ /hr)	163
16	Power input to Pump at duty point (kW)	45.8
17	Prime Mover / Type / Make	Submersible Motor / AQUA
18	Motor Rating (kW)	47
19	Direction of rotation when viewed from drive end	Clockwise
20	Rated Speed (rpm)	1450
21	NPSH Required (m)	N.A. due to flooded suction



Aqua's pumps are in Operation for Cooling Water (CWS) System at NTPC's Ramman Stage – III HEP.



PSP



HEP



Dam/Barrage



Cooling Water (CWS)
(During Operation)

Dry Installed, Flood Proof CW Pumps:

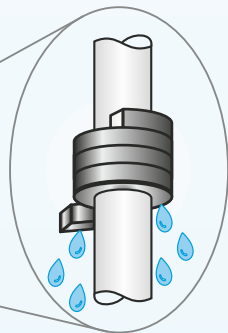
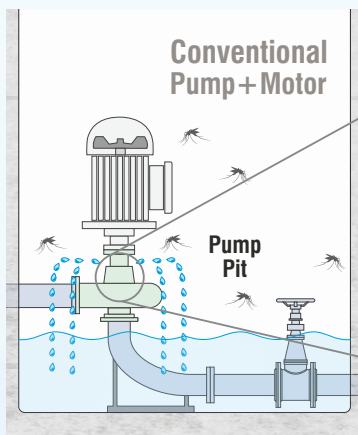
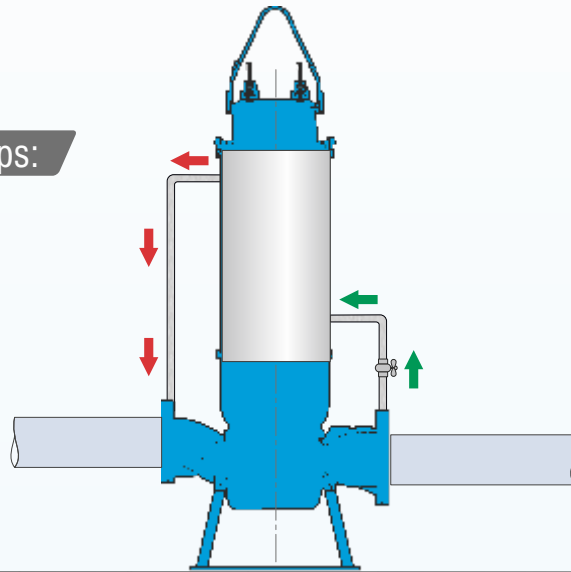

Aqua's Flood Proof Pumpsets are Totally Enclosed (IP68) using either **Glycol** or **Pumped Water** as Coolant to **dissipate** their Heat safely into **Pumped Liquid**...

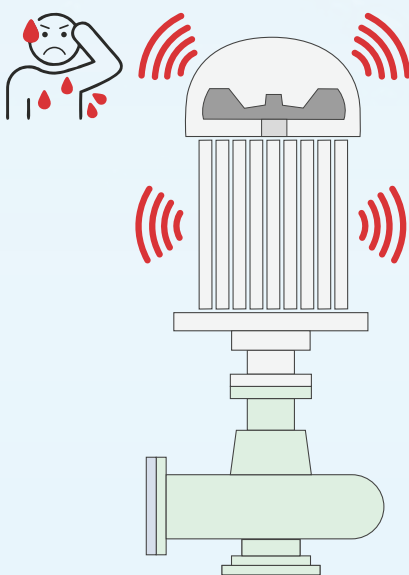

Conventional Pumps use **Air Cooled (TEFC / CACA) motor** which **dissipate** their **Heat & Noise** into the Pit.

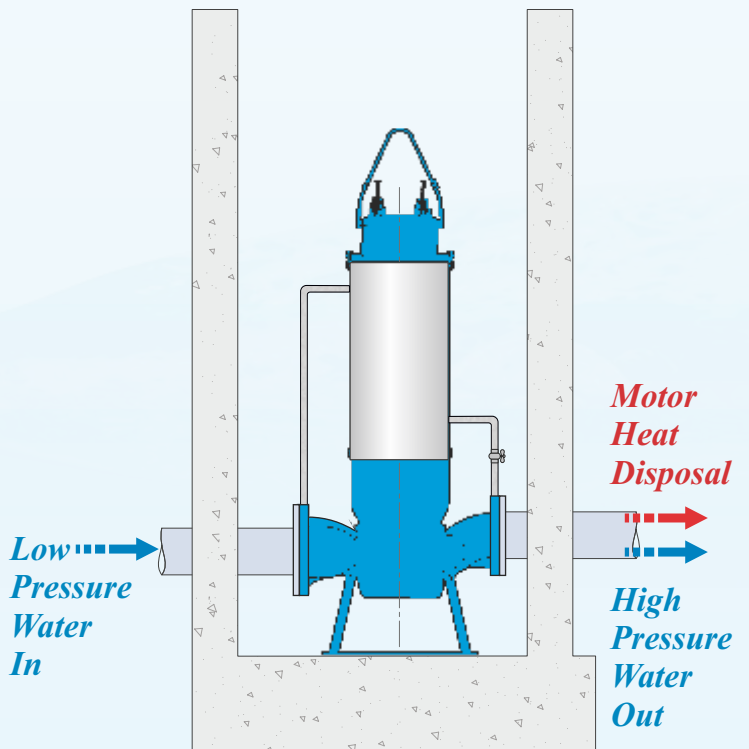

Thanks to the use of Two Ultra High Quality **Mechanical Shaft Seals**, there is **no Nuisance Leakage** (from Pump Gland Rope) into the Pump Pit.



No need of Costly, Maintenance Prone & Energy Consuming **Air Handling Units (AHU)**



...No Breeding ground for Mosquitoes

Improve your Water to Power Output.

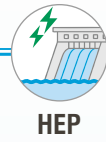

PSP

HEP

Dam/Barrage



Fire Protection
(During Operation)

Aqua's pumps, being Non-Galling & Seizure Resistant will surely Start Up at a moment's notice; even if they've been Left Idle for Extended periods (as is expected from Fire pumps).

Aqua's pumps for Fire Protection System are installed at KABU 16 HEP, Burundi (PMC – WAPCOS INDIA).

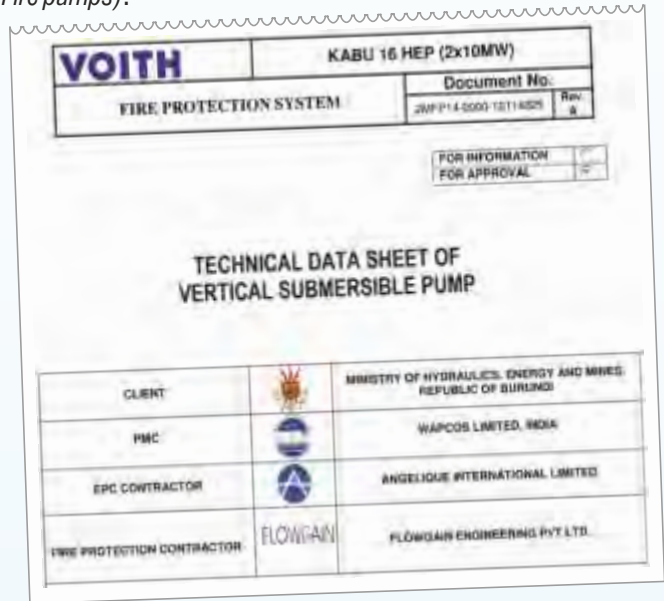

Desilting
(During Operation)

Aqua Pumpsets (both with and without Agitators) are designed for **Desilting of Intakes, Cooling Water Ponds and Reservoirs.**

Aqua's ADS Dredging Pumpsets are used for **Periodic Removal of Silt** from the Cooling Water Sump at Vishnuprayag HEP





PSP

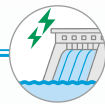

HEP



Dam/Barrage



Desilting
(During Construction)



River Diversion

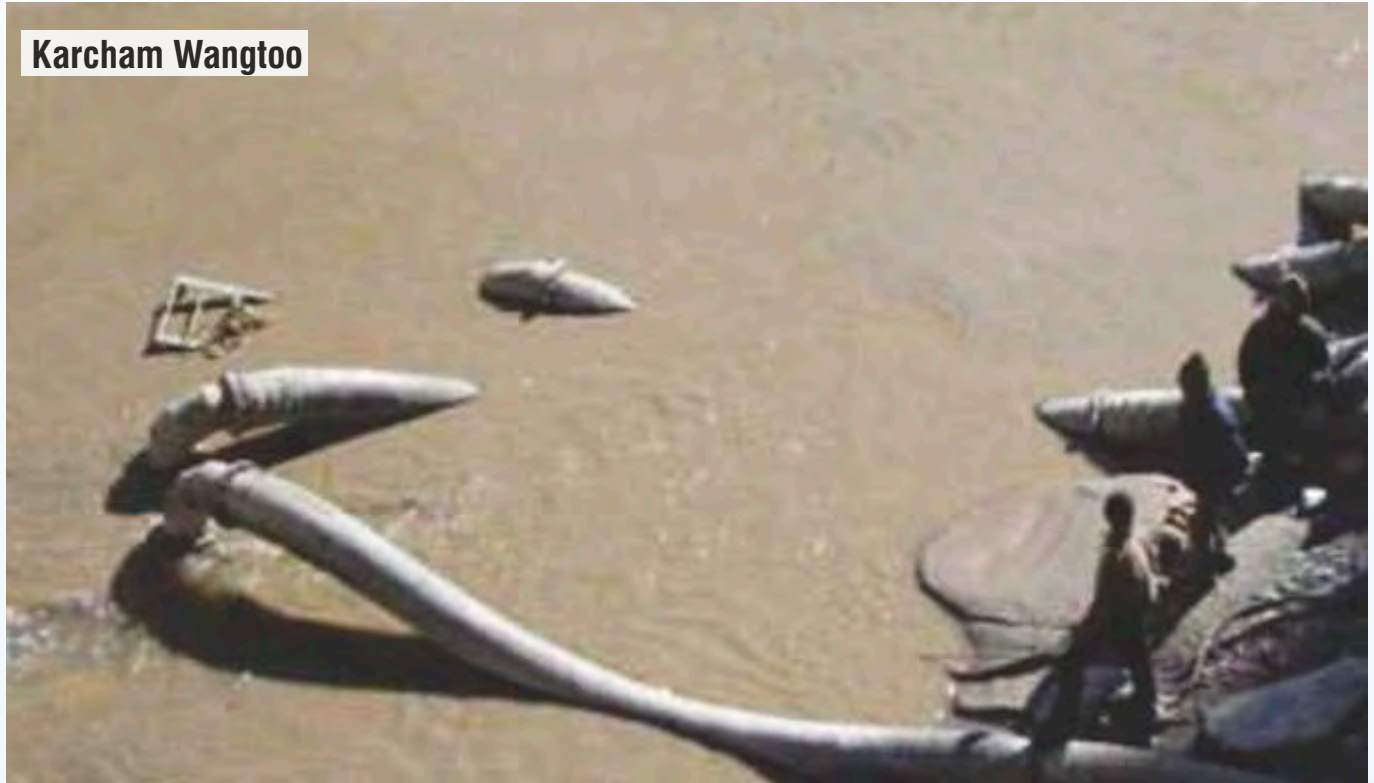

Karcham Wangtoo

Aqua's Non-Clog Slurry Pumpsets are used for **Satluj River Diversion & Evacuating Silt** from the Dam Foundation at Karcham Wangtoo H.E.P.

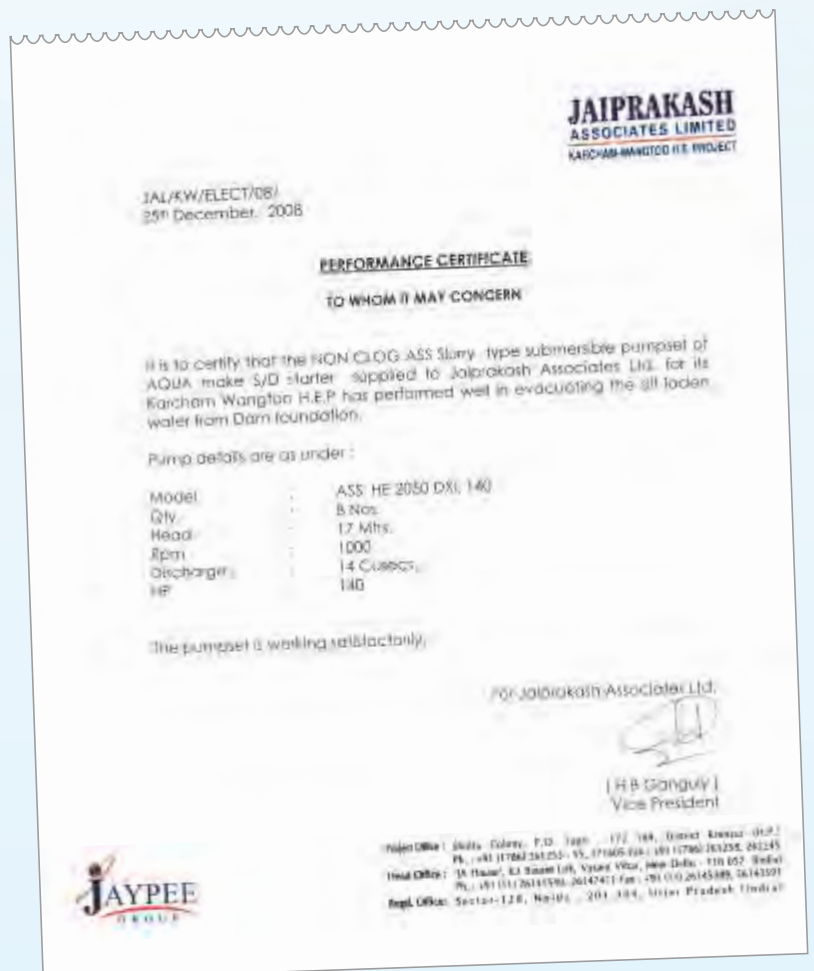

Aqua's (1005 hp @ 3.3kV) Submerged Centrifugal Pumpsets based Floating Pumping Station to lift 18,494m³/hr @ 140m Water for the Initial-fill of the Lower Reservoir at Pinnapuram IREP 1,680 MW



Two large artificial lakes were made for feeding the RPT's which required a Initial charge of **1.4TMC** of water.

Being Artificial Reservoirs, Water for Initial Fill was to be Pumped from nearly **14km** (from Gorakallu reservoir) & at a Static Lift of **96m**



Aqua's Scope of Work

Design, Engineering, Manufacturing, Supply, Installation, Testing & Commissioning of Entire Floating Pumping Station consisting of:

- 1) **SubCF pumpsets** 14W+1S, **1005hp @ 3.3kV** (1321m³/hr x 140m)
- 2) **Pontoons** along with **Walkways**
- 3) **SS Flexible & MS fixed Pipelines**
- 4) **Valves**
- 5) **3.3 KV VCB Panels**
- 6) **1005hp 3.3kV FCMA Soft Starters** with **3.3kV Capacitors**
- 7) **HT & LT Cables**
- 8) **Auxiliary Transformer 3.3 KV/0.415KV**
- 9) **DCDB cum Battery Charger Panel**
- 10) **Earthing etc.**

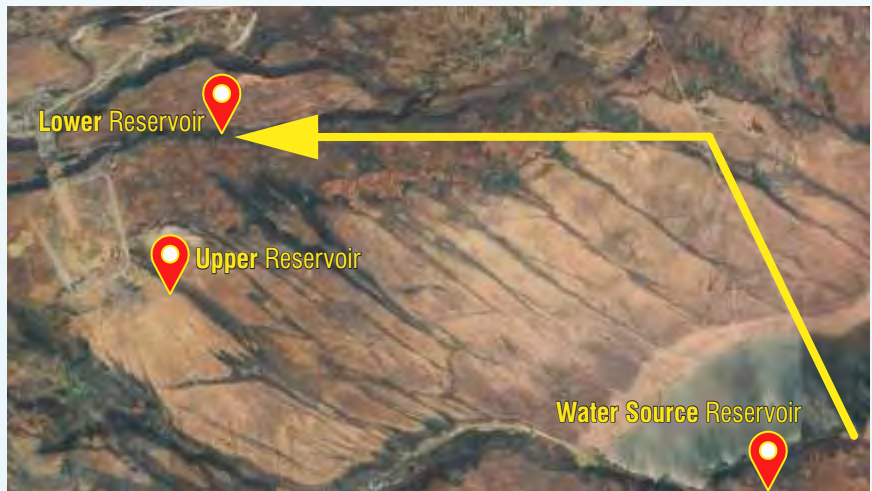



Unforeseen Problem

El Nino nearly Dried-Up Gorakallu Reservoir

Water Shore when the Project was **Conceived** in the **Year 2022**



Receded **Water Shore** when the Project was **Commissioned**

– A **Huge Shift / Depletion**



Despite “**El Nino**” causing unprecedentedly Low Water Level & Drifting of Water Shore away from Planned Off-take point; Thanks to AQUA's System, which could easily Lift Water under such Challenging and Unforeseen Conditions.

Aqua helped the Client Save :

- A. **4 Civil Structures** (including 2 Pumping Stations).
- B. Gestation Time upto **15 months**.
- C. Nearly **₹ 15.25Cr +** in CAPEX.
- D. Nearly **₹ 4.69Cr +** in OPEX Energy in First year itself.
- E. Nearly **₹ 54Cr +** in OPEX Minimum Demand Charges.
- F. Nearly **1 Year of Production Loss** (despite El Nino severely depleting Source Water).



As on date, **GoI's** NHPC Limited has become the largest organisation for hydropower development in India - presently it has an installed base of **8000+ MW**.



Chutak

Project Site	Rating (HP)	Head (m)	Flow (m ³ /hr)	Qty. (No.)	Year of Supply
Teesta V HEP	150	50	420	2	2009
Parbati-III HEP	150	105	180	5	2011
Parbati-III	150	65	300	10	2011
Chutak	65	30	300	9	2011
	15	8	300	2	
	10	20	60	5	
	2	6	18	5	
Teesta IV Low Dam	150	54	388	9	2012
	60	35	240	3	
Dulhasti HEP	150	65	300	2	2014
Dulhasti HEP	150	65	300	1	2015
Chamera-1 HEP	30	35	102	2	2015
Chamera-1 HEP	180	65	400	1	2016
Dulhasti HEP	50	30	240	1	2016
Chutak HEP (4x11 MW)	50	360	21	2	2018
Bairasuil Power Station	100	45	300	8	2019
Bairasuil (3x60 MW)	85	40	300	6	
Rangit HEP	65	27	400	3	2020
Parbati-III HEP	150	65	300	3	2022
Dulhasti Power Station	200	70	400	3	2025
Ratle HEP	235	89	336	7	Under Execution
	235	89	336	3	
	250	82	420	9	
	160	75	336	4	
	70	58	114	4	



Teesta IV Low Dam



Aqua's: References



PSP

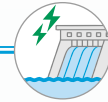

HEP

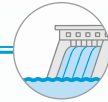

Dam/Barrage







सुभाषी पावर स्टेशन
सिंधुखंड, न्यू & वॉटर - 182006
Dulhasti Power Station
Kishwar (J&K) - 182006
Phone - 01995-209214, 209432
Toll-free: 01995-209261
E-mail: help-desk@nhpc.co.in

No.: NH/DPS/HOP(Sectr.)/2025/ 199 Dated 15.10.2025

Performance Certificate

This is to certify that the following Supply Orders were placed with M/s. Aqua Machineries Pvt. Ltd., Ahmedabad, India, for the supply, installation, Testing and Commissioning of Submersible Slurry Pumps at the Power House of Dulhasti Power Station, Kishtwar (J&K).

1. PO No : NH/DPS/PROC/PR-1347/50-518/2014/2145 Dated: 08/09/2014- having discharge capacity of 300 m3/Hr. at 65 m head, 150 HP, Qty : 2 Nos. Month & Year of Commissioning: January 2015
2. PO No: NH/DPS/PROC/PR-1438/50-574/2015/2870 Dated:16/01/2015- Supply of pumps having discharge capacity of 300 m3/Hr. at 65 mtr. Head, 150 HP, Qty: 01 No. Month & Year of Commissioning: June 2015.
3. PO No: NH/DPS/PROC/PR-1431/50-620/2015/274 Dated:17/06/2015- Supply of pumps having discharge capacity of 400 m3/Hr. at 65 mtr. Head, 180 HP, Qty: 01 No. Month & Year of Commissioning: March 2016.
4. PO No: NH/DPS/PROC/PR-1775/50-980/2019/288 Dated: 12/10/2019- Supply of pumps having discharge capacity of 400 m3/Hr. at 65 mtr. Head, 180 HP, Qty: 03 No. Month & Year of Commissioning: July 2020.
5. PO No : GEMC-S11687720876919 Dated 10/09/2022 - Supply of pumps having discharge capacity of 300 m3/Hr. at 65 mtr. Head, 160 HP, Qty: 02 No. Month & Year of Commissioning: January 2023.
6. PO No. GEMC-S11687789851077 Dated: 12/08/2024 Supply of pumps having discharge capacity of 400 m3/Hr. at 70 mtr. Head, 200 HP, Qty: 03 No. Month & Year of Commissioning: April 2025.

All Pumps were installed successfully, and the performance was found to be satisfactory. We are very satisfied with the After Sales & Service support of AQUA

Gr. General Manager
Dulhasti Power Station

सुभाषी पावर स्टेशन लिमिटेड, सेक्टर-33, फरीदाबाद-121005 (हरियाणा)
Head Office: NHPC Office Complex, Sector-33, Faridkot Road-121005 (Haryana)
CIN No. L14100HRY00001594
Telephone: 0120-2104313(FAX) NHPC A/C: 028-227790
Website: <http://www.nhpc.co.in> email: webmaster@nhpc.co.in





सुभाषी पावर स्टेशन
सिंधुखंड न्यू वॉटर - 182006
Dulhasti Power Station
Kishwar (J&K) - 182006
Phone: 01995-209214, 209432
Toll-free: 01995-209261
E-mail: help-desk@nhpc.co.in

NHPC Limited
(A Govt. of India Enterprise)
(ISO 9001:2015, ISO 14001:2015 & OHSAS 45001:2018 Certified)

Ref: NH/DPS/PHC/DGM/2020/1084 Date:03/06/2020

Installation & Performance Certificate

This is to certify that following Supply Orders were placed to M/s Aqua Machineries Pvt. Ltd., Ahmedabad, India for Supply, Installation, Testing and Commissioning of Submersible Slurry Pumps at Power House of Dulhasti Power Station, Kishtwar (J&K).

1. PO No: NH/DPS/PROC/PR-1438/50-574/2015/2870 Dated: 16.01.2015- Supply of pumps having discharge capacity of 300 m3/Hr. at 65 mtr. Head, 150 H.P, Qty: 01 No. Month & Year of Commissioning: June-2015.
2. PO No: NH/DPS/PROC/PR-1431/50-620/2015/274 Dated: 17.06.2015- Supply of pumps having discharge capacity of 400 m3/Hr. at 65 mtr. Head, 180 H.P, Qty: 01 No. Month & Year of Commissioning: March-2016.

All Pumps were installed successfully and performance of the said pumps is found satisfactory.

By, General Manager (M)
Dulhasti power Station
Kishtwar (J&K)

By, General Manager (PHC)
NHPC Limited
Dulhasti Power Station
Kishwar (J&K) - 182006

सुभाषी पावर स्टेशन में बिजली का काम





सुभाषी पावर स्टेशन
सिंधुखंड, न्यू & वॉटर - 182006
Dulhasti Power Station
Kishwar (J&K) - 182006
Phone - 01995-209214, 209432
Toll-free: 01995-209261
E-mail: help-desk@nhpc.co.in

NH/DPS/PHM/EP/1687 Date: 25.03.2015

To
M/s Aqua Machineries Pvt. Ltd.
Plot No. 382-I, GIDC, Phase-IV,
Vatva, Ahmedabad-382445

Sub: Performance of M/S Aqua Machineries Pvt. Ltd. make Submersible Pump
Ref: Your letter No. AQUA/HO/NHPC/SKM/2013/1091 Date: 04.03.13

With reference to above, it is to intimate that two numbers of M/S Aqua Machineries Pvt. Ltd. make submersible pumps are installed at power house of Teesta-V Power Station as a part of Disaster Management plan during the year 2009-2010. The pumps are not in continuous use. But the testing of the pumps is carried out at regular intervals and the performance during testing is found satisfactory. The detail of the pumps are attached in Annexure-I.

This is for your kind information please.

Thanking you,

Yours sincerely,

By, Manager (E)
Power House Electrical

सुभाषी पावर स्टेशन लिमिटेड, सेक्टर-33, फरीदाबाद-121005 (हरियाणा)
Head Office: NHPC Office Complex, Sector-33, Faridkot Road-121005 (Haryana)
CIN No. L14100HRY00001594
Telephone: 0120-2104313(FAX) NHPC A/C: 028-227790
Website: <http://www.nhpc.co.in> email: webmaster@nhpc.co.in



सुभाषी पावर स्टेशन
सिंधुखंड न्यू वॉटर - 182006
Dulhasti Power Station
Kishwar (J&K) - 182006
Phone - 01995-209214, 209432
Toll-free: 01995-209261
E-mail: help-desk@nhpc.co.in



सुभाषी पावर स्टेशन
सिंधुखंड न्यू वॉटर - 182006
Dulhasti Power Station
Kishwar (J&K) - 182006
Phone - 01995-209214, 209432
Toll-free: 01995-209261
E-mail: help-desk@nhpc.co.in

Ref. No. NH/DPS/PHM/SM(NY)2021-22/51 Date: 25/10/2021

TO WHOM IT MAY CONCERN

This is to certify that M/S Aqua Machineries Private Limited, Survey No. 442/2, 304/1 & 304/2, Near Chandanpur Estate, Near Expressway Highway, Ramol, Ahmedabad-380045 (Gujrat) has supplied 03 Nos. Submersible pumps for drainage and dewatering system of Rangit Power Station vide Supply Order No. NH/RPS/P&C/PHM/P-26/2019-20/518, Dated:- 10/02/2020 placed by Rangit Power Station. The performance of the supplied materials has been found satisfactory.

This certificate is being issued on request of the firm and is meant for participating in tendering purpose only.

By, Sr. Manager (M)
Rangit Power Station,
South Sikkim

सुभाषी पावर स्टेशन | सुभाषी पावर स्टेशन लिमिटेड, सेक्टर-33, फरीदाबाद-121005 (हरियाणा)
Head Office: NHPC Office Complex, Sector-33, Faridkot Road-121005 (Haryana)
सुभाषी पावर स्टेशन में बिजली का काम
Save Energy for Smiles of Self and Nation



PSP

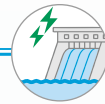

HEP

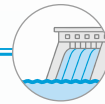

Dam/Barrage



Gol's Maharatna BHEL has the capability to deliver complete hydro power plants in the range of **5 MW** to **300 MW** unit sizes with various **Turbine** types along with matching **Generators** both of which are designed, engineered, manufactured and tested at **BHEL's own manufacturing plants...!**

BHEL has installed more than 1000 utility sets in thermal, hydro, nuclear & gas based power plants, contributing **53%** to the total installed conventional power generation capacity of India..!

Aqua's & BHEL's collaboration began in 2009 with the challenging pumps for NTPC Koldam HEP (80m head in Single Stage installed on Auto Coupling System).

After 100% successful installations, Aqua has; till date supplied cumulatively **10,650 kW** Submerged Slurry pumpsets to BHEL for it's various Indian as well as Export projects.



Koldem HEP

Project Site	Rating (HP)	Head (m)	Flow (m ³ /hr)	Qty. (No.)	Year of Supply	Project Site	Rating (HP)	Head (m)	Flow (m ³ /hr)	Qty. (No.)	Year of Supply
GVK Srinagar HEP	225	41	900	3	2011	Palamuru Rangareddy LIS Stage II & III	235	100	390	2	2021
	85	41	300	1			180	100	240	6	
	65	41	225	1			225	95	390	2	
	30	41	75	2			170	95	240	6	
Grand Katende HEP	90	33	420	3	2016	Palamuru Rangareddy LIS Stage II & III	270	170	240	2	2021
	50	30	240	3			225	135	240	2	
Punatsangchhu-I (6x200MW)	225	70	360	8	2017	Kaleswaram L2P1	75	70	130	4	2022
Punatsangchhu-II (6x170MW)	315	90	360	3	2017		150	70	270	6	
	250	75	372	8			75	60	150	2	
Pranhita Chevella LIS Package-VI (7x127.6 MW)	160	80	270	8	2017		150	60	330	2	
	140	80	210	3		150	90	210	3		
Pranhita Chevella LIS Package-VIII (7x121.5 MW)	160	80	270	9	2017	Kaleswaram L4P2	75	75	130	2	2023
	140	80	210	4			150	80	245	2	
Kameng (4x150 MW)	75	60	150	3	2017	Kaleswaram L4P2	150	90	235	3	
Pranhita Chevella LIS Package-X (4x106 MW)	160	80	270	4	2018	Kaleswaram L4P2	75	85	120	2	2023
	140	80	210	3			150	85	240	2	
Pranhita Chevella LIS Package-XI (4x96 MW)	180	90	270	4	2018	Kaleswaram L4P2	150	96	205	3	
	160	90	210	2							



PSP



HEP



Dam/Barrage





भारत हेवी इलेक्ट्रिकल्स लिमिटेड भोपाल
Bharat Heavy Electricals Limited, Bhopal
 (A Govt. of India Undertaking)
 Tel No. 0755-2603359, Email-rsingh1@bhel.in

Reference No. - HEP / Ratle/DHS/01 Date:-27.09.24

Subject - Certificate for Supply & working of Submersible Pumps

M/S AQUA MACHINERIES PVT LIMITED has supplied submersible pumps to BHEL, Bhopal for 6X170 MW Punatsangchhu-2 HEP, Bhutan as per details below.

Sl.No.	Purchase Order No.	Po Date	Capacity of submersible Pumps.	Quantity	Application
1.	1865168	26.8.2016	6200 LPM X 75 M Head	5 nos	Drainage system
2.	1865168	26.8.2016	6200 LPM X 75 M Head	3 Nos	Dewatering system

Further, as per email dated 26.9.24, received from AGM (PSER) & Construction manager Punatsangchhu-2 site "These Submersible Pumps of M/S Aqua Make have been commissioned and are in service at 6X170 MW Punatsangchhu-II HEP Project, Bhutan. So far the Pumps are working well" (email is attached for reference)

This certificate is issued on vendor request for the purpose of vendor approval in Ratle HEP (4 x 205 MW + 30 MW) project only.

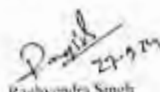
 Ravindra Singh
 Sr DOM / HPE
 (M) 9896502024
 Mr. Anand Kumar D. Gopal
 Sr. B.E. (Pump) P.E. Division
 Aqua & Hy. Division BHEL, Bhopal.



Megha Engineering & Infrastructures Ltd.
 An ISO 9001:2015 Company
 S-2, Technoval Indl. Estate, Balanagar, Hyderabad-500037, Telangana, INDIA
 Tel: +91-40-44336700 Fax: +91-40-44336800
 E-mail: info@meil.in Visit us: www.meil.in U45202TG2D06PLOC60271

Date: 01/01/2025

TO WHOMSOEVER IT MAY CONCERN

This is to certify that, M/s Aqua Machineries Pvt. Ltd. Designed, manufactured, supplied, erected and commissioned at Client premises for PALAMURU RANGAREDDY LIS STAGE 2 & 3 Project.

Pumpset Type : Submerged Pump set with integral motor.

Main Contractor : MEIL, Hyderabad

Pumpset Make : Aqua Machineries Pvt. Ltd, Ahmedabad.

Application : Drain & Dewatering

Pump Model : AVT_V_Su_4st_DR_ES_1543_M_4P_270N_415_NI.

Discharge & Head : 240 M³/hr @ 170 M head

DN Size & Motor Rating: 150 MM & 270 HP

Voltage Level : 415 V

Motor Type : Submerged Squirrel Cage Induction - Dry Air filled Totally Enclosed (IP 68) Self Frame Surface Water Cooled (TESWC) complying to ICA1W0 of IS 6962

Qty : 2 Nos (1W+1S)

Commissioned Year : 2023

These pumps were commissioned in the year of April 2023 and are working satisfactorily till date.

In our experience, these Aqua make submerged pumps are very easy to operate, required almost no maintenance.

 Authorized Signatory

TATA POWER

*Bhira Power House commissioned in the year 1927 is the largest HEP of the Tata Power Co. Ltd. (TPC) & India's **Oldest HEP** (Hydro Electric Power Station)*



HEP's on such Non Perennial rivers (especially those with many surrounding yet non - linked water bodies) can benefit from **Water Harvesting** - water from small streams can be lifted into the main reservoir from where it shall feed the turbine thereby resulting in power generation – against a Minuscule Energy Spent in pumping, Large Energy is Re-Captured from the Turbine Generator **resulting into Net Energy Saving (Generation) which helps reduce Coal Consumption, Carbon Emissions & Improves Profits.**

During monsoon period from the month of Mid-June to September, there are many streams which drain water into the Arabian sea without serving mankind – TPL identified many such streams & came up with a revolutionary concept to pump lift these waters into the main lake from where it would spin the turbine like naturally precipitated rain water.

Rain Water Harvesting for Hydro Electric Power Station

By **Spending** merely **60m Pumping Energy;**
m/s.TPL Extracts 515m worth of **Hydro Electricity**

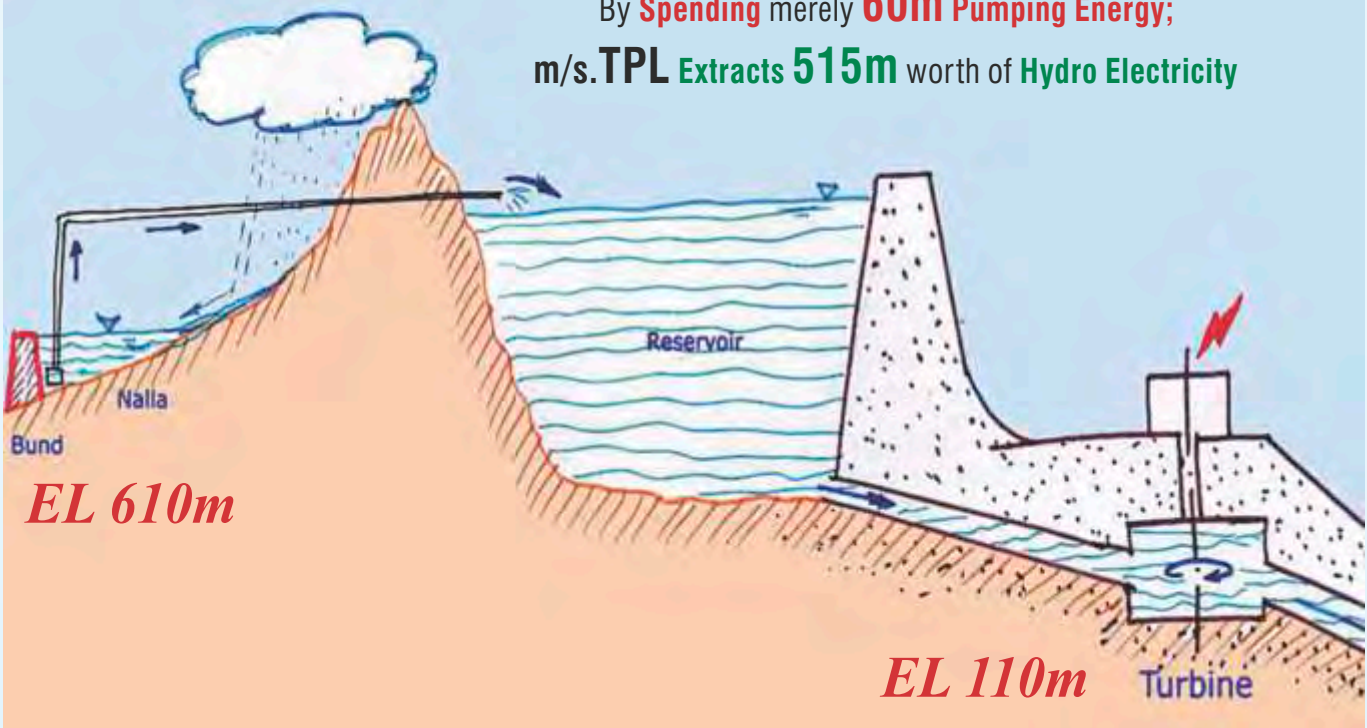



PSP

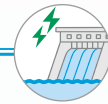

HEP



Dam/Barrage



Project Site	Rating (HP)	Head (m)	Flow (m ³ /hr)	Qty. (No.)	Year of Supply
Bhira HEP PSP	270	60	750	6	2004
	215	60	990	2	
	140	70	335	4	2010
	215	40	1000	4	2010
	100	40	1000	8	
	120	70	300	2	2024
	140	70	333	2	2024





PSP

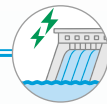

HEP

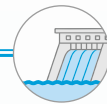

Dam/Barrage

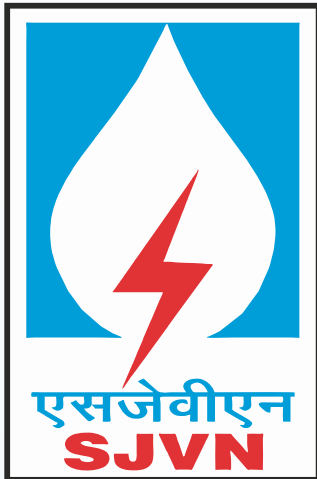

In October **2005**, at India's Largest (1500MW) Hydro Power Station, M/s. Satluj Jal Vidhyut Nigam Ltd. procured an **Imported** "Submersible Sewage" pump (as a part of contingency measures against accidental flooding) at it's **Nathpa Jhakri HEP**.

Just 7 days (after this pump was commissioned), the power house was accidentally flooded – hence to dewater it's UnderGround Power House; this **Imported "Submersible Sewage"** pump was put on continuous duty **but it failed in just 5 hours..!**

Thereafter, m/s SJVNL frantically diverted Aqua pumps from Tata Power Ltd's BHIRA HEP (on loan basis) & the Aqua pumps could successfully dewater the power house (where the Imported pump had failed).

Now SJVNL is using "Aqua" make Submersible Slurry Pumps of capacity **10nos x 300hp @ 80m** – they are running **since 2008** till date **without any single breakdown** in heavy silt (often above 5000 ppm) laden water..!

Project Site	Rating (HP)	Head (m)	Flow (m ³ /hr)	Qty. (No.)	Year of Supply
Nathpa Jhakri HEP (1500MW)	300	80	432	10	2004
	270	60	432	1	
	300	80	432	2	2023
Arun III HEP	180	65	360	18	2023
LUHRI STAGE-1 HEP - 210MW	75	65	90	4	under Execution
	200	65	600	4	
	45	65	90	4	



एसजेवीएन लिमिटेड
SJVNL Limited
A MAATRA COMPANY
Nathpa Jhakri Hydro Power Station

Ref. No. SJVNL/NHPS/PHMM – 599 Dated: 25/09/2024

Performance Certificate

Name of Manufacturer: M/s Aqua Machinerys Pvt. Ltd. Ahmedabad, Gujarat.

LOA No.: SJVNL/NHPS/DSM/P&C/Package-014/D&M/2007/344-50 dated: - 18/04/2007

Capacity: Self-primed centrifugal Pumps, Capacity-220 LPS at 80 M head, Motor 300 HP/1500 RPM along with control panel and 33 mt. Cabin.

Qty: 10 No.

The above said pump sets were installed at Nathpa Jhakri Hydro Power Station (5x250 MW) for Drainage & Dewatering system in year 2008. The performance of Submersible Dewatering Pump sets are found satisfactory.

रम महेश्वरकर
 विद्युत नृप अधिक निगम लिमिटेड

Project Office : Jhansi, District Shimoga-572207
 Tel: 0182 275201, 234102, 275491 www.sjvnl.in
 Corporate H.Q. : Sanku Sadas Jhansi,
 Shimoga-571006 (MH)

SAVE ENERGY FOR BENEFIT OF SELF AND NATION

एसजेवीएन लिमिटेड
SJVNL Limited
A MAATRA COMPANY
Nathpa Jhakri Hydro Power Station

Ref. No. SJVNL/NHPS/PHMM – 599 Dated: 25/09/2024

Performance Certificate

Name of work: Supply of ten (10) nos. 300-hp Aqua make submersible pump (Model No. ASSE 303, 1500 LPS) along with 70 meter cable for Drainage and Flood relief system of NHPS, SJVNL, Jhansi (Package 01) (18/04/2007)

Name of Firm: M/s Aqua Machinerys Pvt. Ltd., IS No. 5047-L, 40277, Near Haldolbari Estate, Near Highway Highway, Ramol, Varanasi, UP-221002

LOA No.: SJVNL/NHPS/PHMM/Package-014/D&M/2007/344-50 dated: - 18/04/2007

Description of Work: Aqua make 300-hp Submersible pump (Model No. ASSE 303, 1500 LPS) Capacity-220 LPS Design Head 80 meter with 70 meter cable for water supply. Motor Rating: 220 KW, 3 Phase, 50% efficiency F (10), 14-1440.

Sr. No.	Sr. No. of Pump	Schedule date of Completion as per IDR	Actual date of Completion	Date of Installation
1	Pump Sr. No. 41208	17/04/2007	14/04/2007	01/05/2007
2	Pump Sr. No. 41209			

This is certified that the above said Aqua make 300-hp Submersible pumps are working properly since installation & the performance of these pumps found satisfactory.

रम महेश्वरकर
 विद्युत नृप अधिक निगम लिमिटेड

Project Office : Jhansi, District Shimoga-572207
 Tel: 0182 275201, 234102, 275491 www.sjvnl.in
 Corporate H.Q. : Sanku Sadas Jhansi,
 Shimoga-571006 (MH)

SAVE ENERGY FOR BENEFIT OF SELF AND NATION



PSP

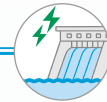

HEP



Dam/Barrage



THDC India Limited

Project Site	Rating (HP)	Head (m)	Flow (m ³ /hr)	Qty. (No.)	Year of Supply
Tehri HEP	50	68	50	3	2010
Koteshwar HEP	130	70	300	2	2012
	120	48	432	1	2013
Tehri Pumped Storage Plant (4 x 250 MW) PSP	200	73	450	3	2016
	215	77	450	3	
	335	75	760	3	
Tehri HEP	300	85	432	2	2018
Pipalkoti HEP	150	50	438	5	-
	100	50	270	3	
	300	85	438	3	
	335	85	438	1	

"हिन्दी को राजभाषा बनाना भाषा का प्रश्न नहीं अपितु देशभक्ति का प्रश्न है"

टीएचडीसी इंडिया लिमिटेड

(भारत सरकार एवं उ.प्र. सरकार का संयुक्त उपक्रम)
टिहरी, टिहरी गढ़वाल, उत्तराखण्ड पिन - 249 131

THDC INDIA LIMITED

(A Joint Venture of Govt. of India & Govt. of U.P.)
Tehri, Tehri Garhwal, Uttarakhand Pin - 249 131

Date: 14.10.2020

TO WHOM SO EVER IT MAY CONCERN

This is to certify that M/s. Aqua Machineries Pvt. Ltd., Ahmedabad has Supplied, Erected, Tested & Commissioned of Submersible Dewatering Pump System for the Flood Preservation Scheme for the Tehri Hydro Power Plant (HPP), against agreement No 27/DGM/C&MM/THDC/TEHRI/2016-17 Dt.23.06.2016

The Pump set particulars Supplied against the agreement are as following:

Pumpset Type	: Submerged Dewatering / Slurry Pumpset with Integral Motor
Application	: Dewatering Pump System for the Flood Preservation Scheme
Qty	: 2 Nos.
Head	: 85 meter
Flow	: 432 m ³ /hr
Motor Rating	: 300 HP / 225 kW
Voltage	: 415 V

The Pump system was commissioned during Dec'2018 and the performance found satisfactorily since installation.

This certificate is being issued on the request of the firm.

A.G.M (O&M)
 THDC INDIA LIMITED,
 Tehri-Garhwal.

Project Engineer (HPP)

प्रधान कार्यालय - गंगा भवन, प्रगतपुरम, बाई पास रोड, ऋषिकेश 249 201, दूरभाष : 2431517, 2431522, 2431523 फैक्स : 0135.2431520
 Head Office: Ganga Bhawan, Pragatipuram, Bypass Road, Rishikesh-249 201 Tel: 2431517, 2431522, 2431523 Fax : 0135-2431520
 परकीर्ण कार्यालय - भगीरथी भवन (टॉप टेरस) भगीरथीपुरम, टिहरी - गढ़वाल - 249 131
 Regd. Office : BHAGIRATHI BHAWAN (TOP TERRACE) BHAGIRATHIPURAM, TEHRI-GARHWAL-249 131
 Phone : 01376-266391-92-93-94-95, Fax :- 01376-236363

THDC India Limited, is a Public Sector Enterprise under the administrative control of the Ministry of Power (MoP), Government of India (GoI) to develop, operate & maintain 2747MW

27

Filyer : PSP, HEP & Dams Prod & Creds_r5



PSP

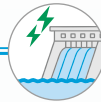

HEP



Dam/Barrage



The HEP's developer, (ANDRITZ) had supplied Ritz make **German** (*Non Clog Sewage Submersible*) pumps (*as a part of its BoP commitment*) to this HEP but these fragile pumps ran into frequent problems (*due to heavy Silt & Calcites*).

Realizing the need for Robust Engineered pumps, both the Developer & the Client; since then have **replaced the German pumps with Aqua** (& permanently shifted over to Aqua for newer demand) & are very satisfied with the same....

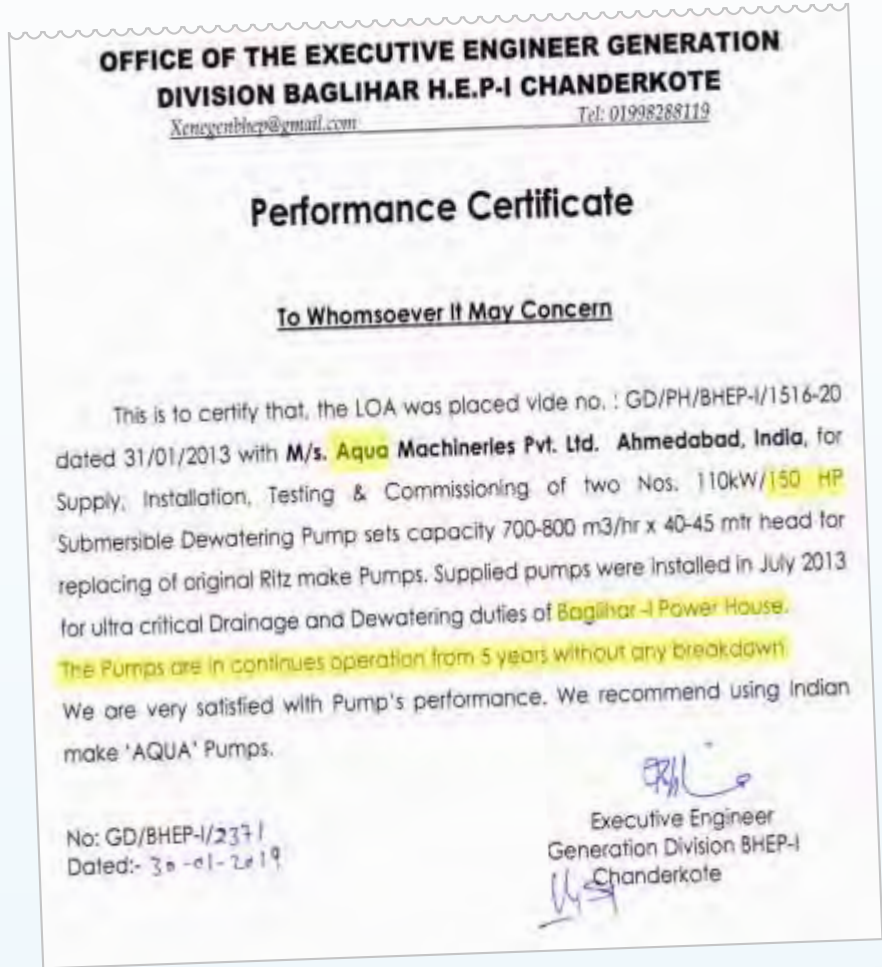

Project Site	Rating (HP)	Head (m)	Flow (m ³ /hr)	Qty. (No.)	Year of Supply
Baglihar HEP 1&2	150	45	800	2	2013
	150	45	800	1	2018
	150	62	360	3	2018
	200	67	450	2	2020
	150	45	700	1	2024

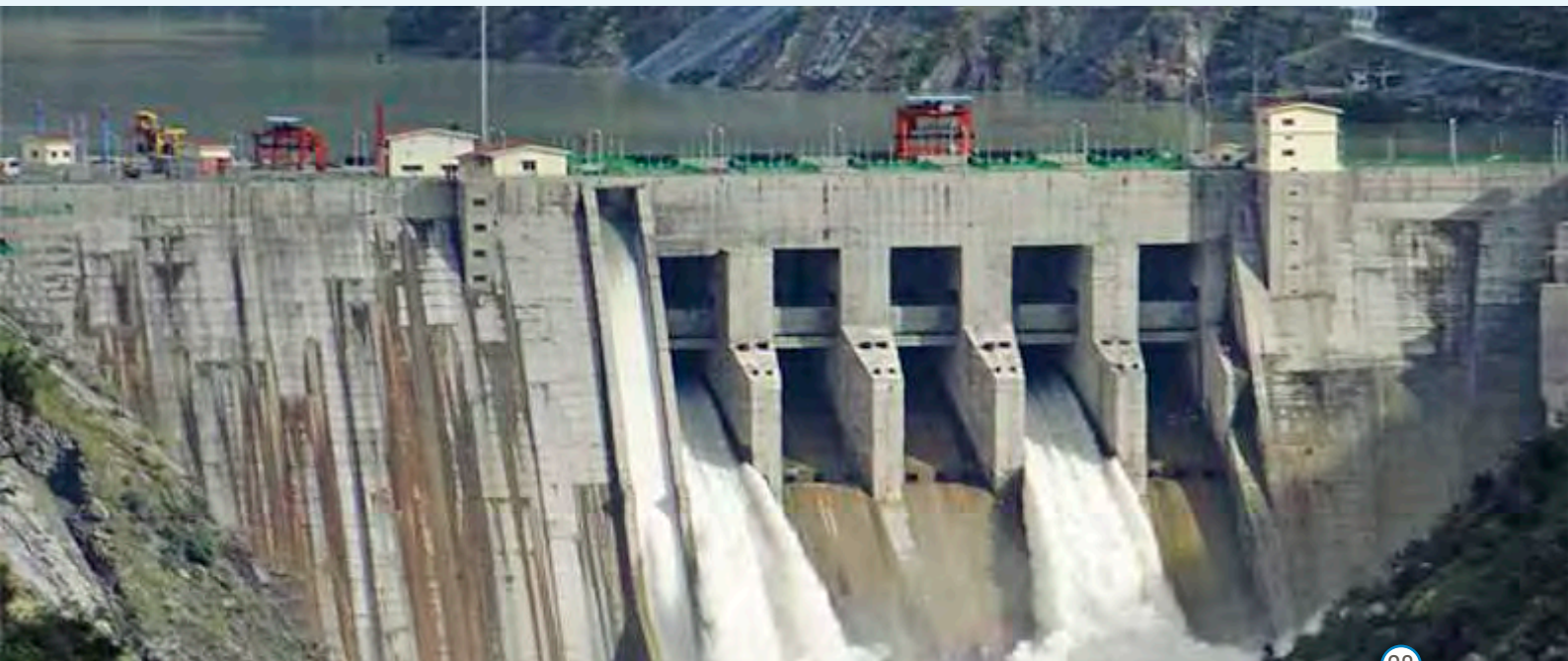



PSP

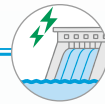

HEP

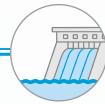

Dam/Barrage



NTPC Limited, formerly known as National Thermal Power Corporation Limited, is an Indian government electricity board engaged in the business of generation of electricity and the company contributes to over 25% of total power generation.

AQUA's has supplied pumpsets to it's both HEP's - Koldam & Rammam.

Project Site	Rating (HP)	Head (m)	Flow (m ³ /hr)	Qty. (No.)	Year of Supply
Koldam HEP	50	80	60	3	2008
	50	80	60	2	2016
	50	80	60	2	2016
	50	80	60	2	2017
	50	80	60	2	2018
	50	80	60	2	2019
	50	80	60	2	2022
	50	80	60	3	2025
Rammam-III HEP (3x40 MW)	90	30	426	6	2019



Project Site	Rating (HP)	Head (m)	Flow (m ³ /hr)	Qty. (No.)	Year of Supply
Tuirial HEP	50	42	150	5	2015
KAMENG HEP (4x150MW)	75	60	150	3	2017
Dikrong PH	70	45	250	1	2010
Tuirial HEP	50	42	150	1	2021
Turial HEP (2x30 MW)	50	42	150	2	2016



Project Site	Rating (HP)	Head (m)	Flow (m ³ /hr)	Qty. (No.)	Year of Supply
Nagarjuna Sagar Tali Pond Dam (2x25MW)	75	75	140	3	2014
Nagarjuna Sagar Power House	175	42	742	2	2023
Srisaillam	45	30	180	1	2009



APGenCo are using Aqua pumpsets for their **Nagarjuna Sagar Tail Pond Dam** since **2014** without a single maintenance issue till date..!





Aqua's: References



PSP

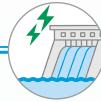

HEP



Dam/Barrage



GUJARAT STATE ELECTRICITY LTD.



Sardar Sarovar Narmada Nigam Ltd.

The Sardar Sarovar Project is one of the largest water resources project of India - the dam's spillway (discharging capacity 30.7 lakhs cusecs) would be **3rd highest in the World** & it has an installed capacity of 1200MW (6 x Francis RPT x 200 MW).

They are using Aqua make **400hp** x 70m Head x **1020m³/hr** - effectively the **Largest capacity** Submerged pumpsets used in any Indian HEP.

Form 3(A)

WORK WISE DETAILS OF WORK COMPLETED BY THE CONTRACTOR

- Name of contractor:- M/s Aqua Machineries Pvt. Ltd, Ahmedabad.
- Name of work - Design, supply, installation & commissioning of High capacity submersible pump and its auxiliaries for Disaster management point of view at SSHEP RBPH K' colony
- LOI No. :- GSECL/SSHEP/CE(O&M)/F/RBMM/WL-11/18-19/LOI/1073 Dtd. 14/05/2018
- Work order no :- GSECL/SSHEP/CE(O&M)/F/RBMM/WL-11/ WO / 1607 Dtd 21.07.2018
- Estimated cost of work put to tender :- 2,50,00,000.00
- Tender amount:- 2,45,00,000.00
- Date of starting of work :- 01.08.2018
- Time Limit - 06 Months
- Time Limit Extension:- NA
- Date of completion of the work :- 30.11.2018
- Actual date of the completion of work:- 31.01.2019
- Amount of work as per final bill :- 2,45,00,000.00

 Signature & Seal of contractor

- State whether the details as above given by the contractor are correct. If not state as to what is the correct information:-
:- The above details are correct as per record
- State whether the contractor has executed the work satisfactorily as per specification has completed the work satisfactorily as per specification if not give comment position of the work
:- Work completed satisfactory.
- Any other remarks (Product details)
:- Application - Dewatering of Hydr Power House
Head: 70 mtr
Flow : 1020 m³/hr
HP : 400 HP
Qty. 2 Nos.

Performance of above supplied Pumpsets are satisfactory till date

 Addl. Chief Engineer (O&M),
 GSECL, SSHEP, Kevadia Colony.

No. CE/GSECL/SSHEP(O&M)/RBPH E&M/3-A/ Date : 20 JAN 2021
 000224

To,
 M/s Aqua Machineries Pvt. Ltd,
 Survey No. 442/2, 504/1 & 504/2, Near Handarshan Estate,
 Near Express Highway, Ramol, Ahmedabad-382445



Based on the very satisfactory performance of GE-Alstom's supplied Aqua pumpsets, Odisha Hydro Power Corporation Ltd. have given Repeat yet Direct order to Aqua.

Project Site	Rating (HP)	Head (m)	Flow (m ³ /hr)	Qty. (No.)	Year of Supply
Hirakud	140	30	820	1	2017
					2020



UJVN Limited

(A Govt. of Uttarakhand Enterprise)

Project Site	Rating (HP)	Head (m)	Flow (m ³ /hr)	Qty. (No.)	Year of Supply
Shahpurkandi	55	38	210	4	2024
	160	38	660	4	

Project Site	Rating (HP)	Head (m)	Flow (m ³ /hr)	Qty. (No.)	Year of Supply
Chilla HEP	130	30	720	2	2024
	50	30	240	2	
	100	30	240	1	

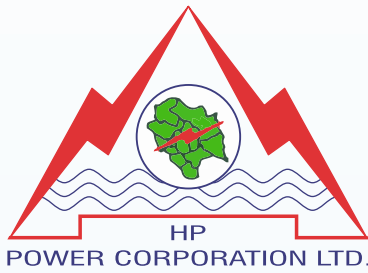

Himachal Pradesh POWER CORPORATION LIMITED

Project Site	Rating (HP)	Head (m)	Flow (m ³ /hr)	Qty. (No.)	Year of Supply
Shongtong Karchham HEP (3x150 MW)	100	50	270	10	2020

VOITH

Engineered Reliability

Voith Hydro (formerly Voith Siemens Hydro Power Generation) is a joint venture between Voith and Siemens, which is a system supplier for 1/3rd of the world's hydroelectric power being produced with its turbines & generators. Voith has chosen our Pumpsets for its various Projects.

Project Site	Rating (HP)	Head (m)	Flow (m ³ /hr)	Qty. (No.)	Year of Supply
Sainj	50	35	120	2	2013
Singoli Bhatwari	20	30	45	2	2017
	35	30	175	2	
Bhasmey (2x27 MW)	10	26	10	1	2013
	15	25	45	3	
Rongnichu (2x48MW)	12.5	15	120	2	-
	6	15	60	2	
	3	15	15	2	



ALAKNANDA HYDRO POWER COMPANY LIMITED (Formerly DUNCANS NORTH HYDRO POWER COMPANY LTD.)

Performance Certificate

To Whomsoever it May Concern

This is to certify that, M/s. Bharat Heavy Electricals Ltd. has supplied following capacity AQUA make (M/s. Aqua Machineries Pvt. Ltd. Ahmadabad) Heavy Duty Submersible Pump sets for Alaknanda Hydro Electric Project for Drainage, Dewatering & Flood Dewatering Applications.

Head: 42 mtr
Flow: 900 m³/hr
HP/KW: 2115 HP/1512 KW
Qty: 3 No.

We are using above supplied pump sets since April 2013. We are very satisfied with Performance of above supplied pump sets for ultra critical Slurry Water Dewatering. We recommended using Indian "AQUA" Make Pump sets for D&D application of Hydro Power Stations.

For Alaknanda Hydro Power Company Ltd.

Authorized Signatory

Koteshwar Colony, Srinagar, Dist. Pauri Garhwal - 246174
Tel: (91-1348) 244330, TeleFax: (91-1348) 244336, Email: - Alp.purchasing@gvk.com

Alaknanda HEP





Aqua's: References



PSP

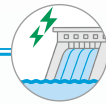

HEP

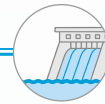

Dam/Barrage



GE (USA) acquired Alstom's (France) power generation & by 2018 their power plants produced **1/3rd** of the **World's** electricity...!

After trying virtually every make, GE (Alstom) have now almost informally standardized on Aqua's pumpsets for their South Asian HEP's ..!

ALSTOM

Project Site	Rating (HP)	Head (m)	Flow (m ³ /hr)	Qty. (No.)	Year of Supply	Project Site	Rating (HP)	Head (m)	Flow (m ³ /hr)	Qty. (No.)	Year of Supply
Jorethang HEP	60	36	204	3	2008	Tehri Pumped Storage Plant (4 x 250 MW)	5	12	40	2	2016
	50	40	110	3	2012		20	41	35	2	
Dikchu HEP	40	25	175	2	2013	Tashiding Hydro Electric Project	45	36	150	2	2016
	50	23	265	4			100	38	450	2	
CHUZACHEN HEP	20	23	80	4	2013	Hirakud Hydro Electric Project	140	30	820	2	2016
Tehri Pumped Storage Plant (4 x 250 MW)	200	73	450	3	2016						
	215	77	450	3							
	335	75	760	3							



GE Power India Limited

Project Site	Rating (HP)	Head (m)	Flow (m ³ /hr)	Qty. (No.)	Year of Supply
Lower Solu Hydro Electric Project	6	415	14	35	2018
	6	415	14	35	
	2	415	17.5	5	
Baleh Hydro Electric Project	200	415	55	560	2025

ANDRITZ Hydro

ANDRITZ Hydro is one of the leading global suppliers of electro-mechanical equipment and services for hydropower plants with a total capacity of more than 21,000 MW in India.

Project Site	Country	Rating (HP)	Head (m)	Flow (m ³ /hr)	Qty. (No.)	Year of Supply	Project Site	Country	Rating (HP)	Head (m)	Flow (m ³ /hr)	Qty. (No.)	Year of Supply
OPGCL_Middle Bhotekoshi (102 MW)	Nepal	75	25	468	2	2017	Baglihar-II	India	150	62	360	3	2018
		40	25	234	2		Regional Rusumo Falls	Tanzania	35	32	100	2	2019
DAK MI-2	Vietnam	25	28	100	2	2017			Nam Kong-3	Laos	100	37	
		22.5	20	150	2		12.5	37			30	3	
Nam Theun 1	Laos	50	57	90	5	2019	Shongtong Karchham (3x150 MW)	India	100	50	270	10	2020
		450	58	1260	4	2018							
		200	50	630	4								
Thuong Kon Tum (2x110 MW)	Vietnam	35	30	150	1	2018							



PSP

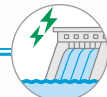

HEP



Dam/Barrage



adani
Renewables

Adani Green Energy Limited

Project Site	Rating (HP)	Head (m)	Flow (m ³ /hr)	Qty. (No.)	Year of Supply
Chitravati PSP	150	85	234	6	2025
	122	70	234	3	

JAIPRAKASH POWER VENTURES LIMITED



Jaypee Ltd. has used our pumpsets for Dewatering during the **Dam Construction** of its KarchamWangtoo, & River Dimension Baglihar, & Omkareshwar HEPs.

Vishnuprayag Hydro Electricity Project uses Aqua's ADS Dredging pumpsets are used for periodic removal of Silt from the Cooling Water Sump.

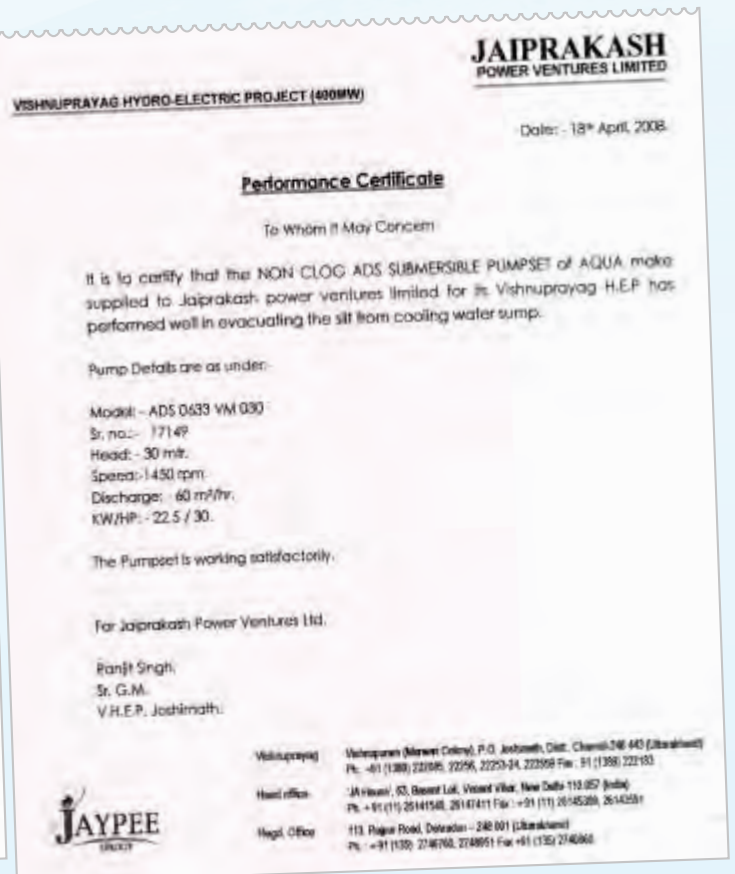



Aqua's: References



PSP

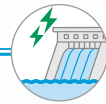

HEP



Dam/Barrage



Rugged Pumps
Robust Solutions
Reliable People

A Globally Unbeatable Range of Submerged Pumps:

upto 750 m

upto 13.2 kV

upto 3000 kW

upto 40,000 m³/hr

SEGMENTS



Drinking Water



Water Transportation



Irrigation



Storm Water



Sewage

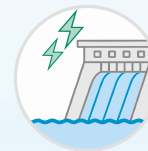

Hydro Power



Thermal Power



Mining



Sea



Industry



Construction



Building



Aqua Machineries Pvt. Ltd.

www.aquapumps.com

Registered Office & Manufacturing Plant

Survey No. 504/1-2, 442/2, Near Haridarshan Estate, Near Express Highway,
Ramol, Ahmedabad-382 445. Gujarat, India.



www.aquapumps.com